

# MW150L Windsor Large

# MW150L Windsor Large



## Product Description

The Windsor Large Lantern was designed to bring the popular style of a Victoria lantern to a suitable standard that would be able to cope with and endure the modern day environment and the high demands placed upon a street lighting luminaire today. The design brief demanded a lantern that was robust, simple to maintain, efficient, flexible and styled in such a way as to replicate the design of a bygone era. The demands and needs of both public and private sectors for a vandal resistant, decorative traditional luminaire that satisfied the scrutiny of the conservationists was a tall order but one that was and is, more than satisfied by the Windsor Large lantern.

## Product Features

### Dimensions

Height: 849mm | Width 455mm

### Construction

Hood: Cast Aluminium

Frame: Cast Aluminium

Frog: Cast Aluminium or Fabricated

Weight: 14Kg

IP Rating: 66

IK Rating: 10

### Glazing

One-piece UV stabilized, clear polycarbonate bowl as standard. Structured, frosted, tinted & opal glazing available on request.

### Finish

Polyester powder coat to any BS or RAL colour. glazing available on request.

### Gear

- Mercury
  - Metal Halide
  - Sodium
  - LED up or down light
- All lamps & gear can be catered for.

### Optics

- SGS203
- SGS252
- SGS253
- Refractor
- Louvre

### Photocell

All photocells can be catered for

### Mounting

Top, bottom & cradle  
Column & wall

### Guarantee

30 years as standard



# MW150L Windsor Large Lantern Mounting Options

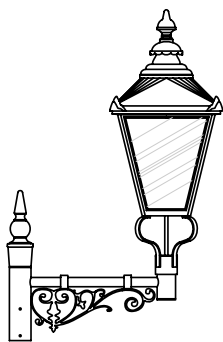

POST TOP BRACKET  
BOTTOM FIXED LANTERN



STEEL FROG



CAST FROG

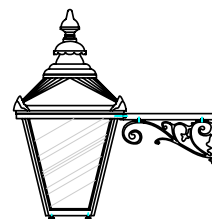

WALL FIXED BRACKET  
CRADLE MOUNTED LANTERN

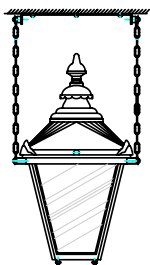

CEILING SUSPENDED  
CRADLE MOUNTED LANTERN

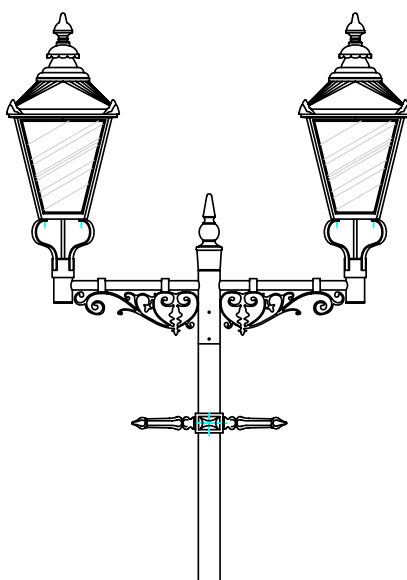

POST TOP BRACKET  
BOTTOM FIXED LANTERNS  
TWINS & TRIPLES

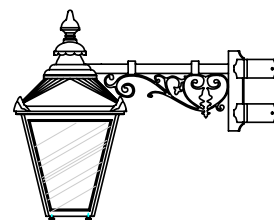

CORNER BRACKET  
TOP FIXED LANTERN

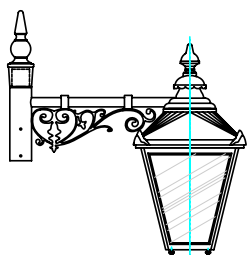

POST TOP BRACKET  
TOP FIXED LANTERN

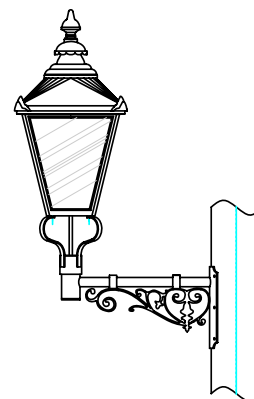

POST FIXED BRACKET  
BOTTOM FIXED LANTERN



**PHILIPS**  
Lamps, Gear & Optics  
used as standard

0800 368 7633

[www.msdlighting.co.uk](http://www.msdlighting.co.uk)

[sales@msdlighting.co.uk](mailto:sales@msdlighting.co.uk)

**msd** Lighting  
Consultants & Manufacturers